



## Silicon Carbide Schottky Diode

### ➤ Features

VR	IF	VF
650V	10A	1.4V

### ➤ Pin Configuration

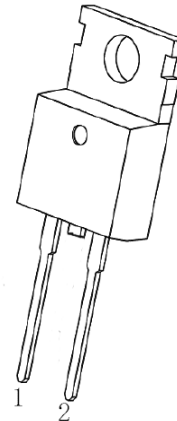

### ➤ Description

- 650V Schottky Rectifier
- High Frequency Operation
- Extremely Fast Switching
- Positive Temperature Coefficient on  $V_F$



### ➤ Applications

- Power Supplies
- Power Factor Correction
- Motor Drives

### ➤ Ordering Information

Device	Package	Shipping
SSC65010AT3	TO220-2L	1K/Box

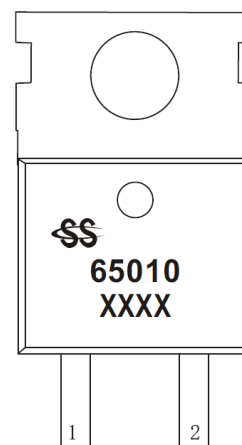

Marking

(XXXX: Year/Week)



➤ **Absolute Maximum Ratings**(TA=25°C unless otherwise noted)

Symbol	Parameter		Ratings	Unit
V <sub>RRM</sub>	Repetitive Peak Reverse Voltage		650	V
V <sub>RSM</sub>	Surge Peak Reverse Voltage		650	V
V <sub>DS</sub>	DC Blocking Voltage		650	V
I <sub>F</sub>	Continuous Forward Current	T <sub>c</sub> =150°C	10	A
I <sub>FRM</sub>	Repetitive Peak Forward Surge Current <sup>A</sup>		45	A
I <sub>FSM</sub>	Non-Repetitive Peak Forward Surge Current <sup>A</sup>		90	A
I <sub>F MAX</sub>	Non-Repetitive Peak Forward Surge Current <sup>B</sup>		860	A
P <sub>TOT</sub>	Power Dissipation	T <sub>c</sub> =25°C	136	W
T <sub>J</sub> T <sub>STG</sub>	Operating Junction and Storage Temperature		-55~+175	°C

➤ **Thermal Resistance Ratings**(TA=25°C unless otherwise noted)

Symbol	Parameter	Ratings	Unit
R <sub>θJC</sub>	Thermal Resistance Junction-to-Case	1.1	°C/W

Note:

A. T<sub>c</sub>=25°C,t=10ms,Half Sine Wave;

B. T<sub>c</sub>=25°C,t=10us,Pulse;



## SSC65010AT3

➤ **Electronics Characteristics**(TA=25°C unless otherwise noted)

Symbol	Parameter	Test Conditions	Typ.	Max.	Unit
V <sub>F</sub>	Forward Voltage	IF=10A TJ=25°C IF=10A TJ=175°C	1.4 1.75	1.7 2.1	V
I <sub>R</sub>	Reverse Current	VR=650V TJ=25°C VR=650V TJ=175°C	2 40	20 200	uA
Q <sub>C</sub>	Total Charge	VR=400V IF=10A TJ=25°C	28		nC
C	Total Capacitive	VR=0V TJ=25°C f=1MHz VR=200V TJ=25°C f=1MHz VR=400V TJ=25°C f=1MHz	550 53 48		pF
E <sub>C</sub>	Capacitance Stored Energy	VR=400V	7		uJ



➤ Typical Characteristics (TA=25°C unless otherwise noted)

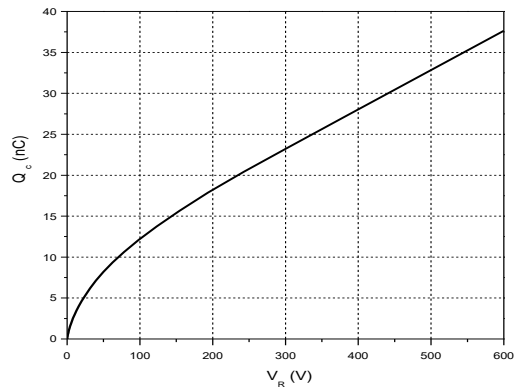
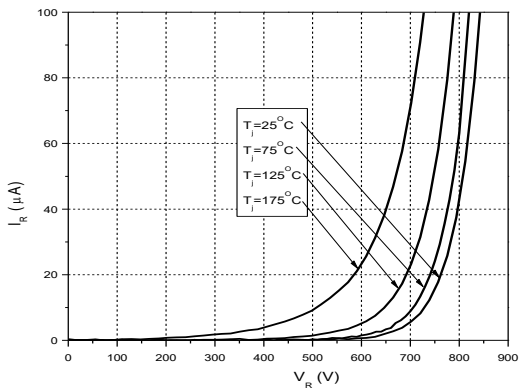
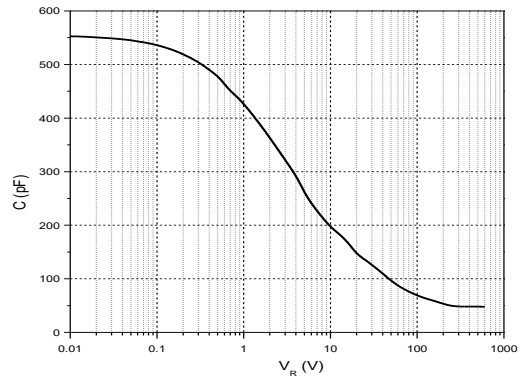
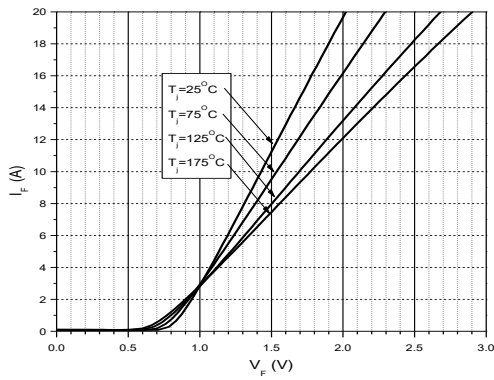



➤ Package Information

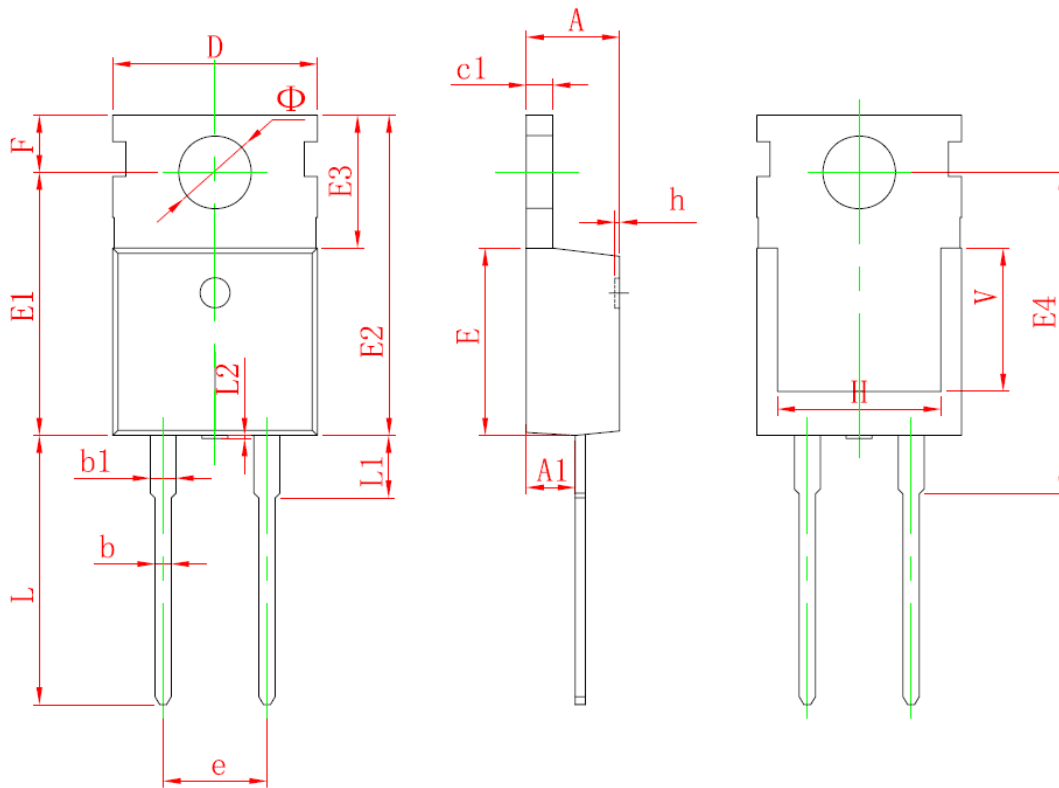

Symbol	Dimensions In Millimeters		Dimensions In Inches	
	Min.	Max.	Min.	Max.
A	4.400	4.600	0.173	0.181
A1	2.250	2.550	0.089	0.100
b	0.710	0.910	0.028	0.036
b1	1.170	1.370	0.046	0.054
c	0.330	0.650	0.013	0.026
c1	1.200	1.400	0.047	0.055
D	9.910	10.250	0.390	0.404
E	8.950	9.750	0.352	0.384
E1	12.700	13.000	0.500	0.512
E2	15.500	15.800	0.610	0.622
E3	6.350	6.650	0.250	0.262
E4	15.750	16.050	0.620	0.632
e	4.980	5.180	0.196	0.204
F	2.650	2.950	0.104	0.116
H	7.900	8.100	0.311	0.319
h	0.000	0.300	0.000	0.012
L	12.900	13.400	0.508	0.528
L1	2.850	3.250	0.112	0.128
L2	0.050	0.300	0.002	0.012
V	6.900 REF.		0.272 REF.	
Φ	3.400	3.800	0.134	0.150



**DISCLAIMER**

AFSEMI RESERVES THE RIGHT TO MAKE CHANGES WITHOUT FURTHER NOTICE TO ANY PRODUCTS HEREIN TO IMPROVE RELIABILITY, FUNCTION OR DESIGN. AFSEMI DOES NOT ASSUME ANY LIABILITY ARISING OUT OF THE APPLICATION OR USE OF ANY PRODUCT OR CIRCUIT DESCRIBED HEREIN; NEITHER DOES IT CONVEY ANY LICENCE UNDER ITS PATENT RIGHTS, NOR THE RIGHTS OF OTHERS.

THE GRAPHS PROVIDED IN THIS DOCUMENT ARE STATISTICAL SUMMARIES BASED ON A LIMITED NUMBER OF SAMPLES AND ARE PROVIDED FOR INFORMATIONAL PURPOSE ONLY. THE PERFORMANCE CHARACTERISTICS LISTED IN THEM ARE NOT TESTED OR GUARANTEED. IN SOME GRAPHS, THE DATA PRESENTED MAY BE OUTSIDE THE SPECIFIED OPERATING RANGE (E.G. OUTSIDE SPECIFIED POWER SUPPLY RANGE) AND THEREFORE OUTSIDE THE WARRANTED RANGE.